

PLAN OF THE FRAME
STOCK NO. 9721-0630

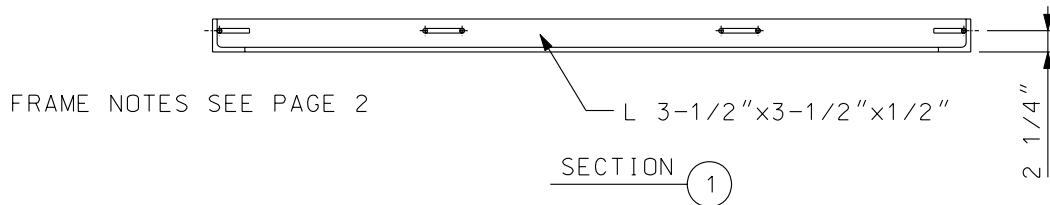

FRAME NOTES SEE PAGE 2

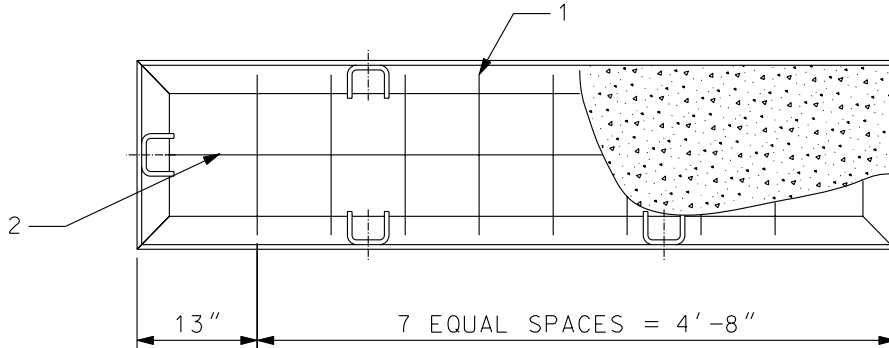

STOCK NO. 9721-0646

ROD NO	1	2
QUANTITY	8	1
SIZE	#3	#3
LENGTH	1'-5"	6'-4"

SIDEWALK SLAB NOTES:

- 1: THE REBAR SHALL BE EPOXY AND INSTALLED INTO THE FRAME AS SHOWN.
- 2: CONCRETE SHALL THEN BE TROWL FINISHED FLUSH WITH THE TOP EDGE FRAME.
- 3: SDWK SLAB WEIGHT = 500 LBS
- 4: 3 CU.F.T OF 4000PSI CONCRETE
- 5: REV A: CHANGED DWG FORMAT.

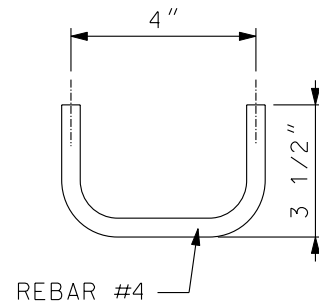

DETAIL A
1" = 5"

WELDING SPECIFICATIONS SEE PAGE 2

DRAWN: LKD DVLPEP: CER DATE: 2/10/82 REVIEWED: TWM DATE: 8/8/08 APPRVD: MDW DATE: 8/29/08 NEXT REVIEW: 8/11 REV: B



DISTRIBUTION
STANDARDS

1'-6" x 6'-10" FLUSH TYPE ROOF
SLAB FOR SIDEWALK MANHOLES

FRAME NOTES:

- 1: MITER AND WELD ALL CORNERS 90 GRIND OFF ANY HIGH SPOTS ON THE FLANGE SURFACES TO ALLOW PROPER SEATING OF FRAME.
- 2: FINISHED FRAME IS TO HAVE ALL CORNERS ON THE SAME PLANE AND IS NOT TO BE TWISTED OR BENT
- 3: FRAME TO BE GALVANIZED AFTER SHOP WORK AND SHALL CONFORM TO A.S.T.M SPECIFICATION A-123 WITH LATEST REVISIONS THEREOF.
- 4: THIS FRAME SHALL BE LIMITED TO SIDEWALK USE WITH MAXIMUM CLEAR SPAN BETWEEN SUPPORTS OF 6'-4".
- 5: FRAME WEIGHT = 170 LBS
- 6: REV A: CHANGED DWG FORMAT & CHANGED STOCK NO'S PER WMIS.

WELDING SPECIFICATONS:

- 1: ALL STRUCTURAL STEEL SHALL CONFORM TO ASTM A36.
- 2: ALL STEEL IS TO BE WELDED IN ACCORDANCE WITH AWS D1.1 USING EITHER THE SMAW PROCESS (AWS SPEC. A5.1) OR TH FCAW PROCESS (AWS SPEC. A5.20 OR A5.29).
- 3: ALL WELDING IS TO BE PERFORMED ACCORDING TO WELDING PROCEDURE SPECIFICATIONS PFAB200601,PFAB200602,AND PFAB200603.
- 4: ALL WELDERS ARE TO BE QUALIFIED ACCORDING TO AWS D1.1.
- 5: ALL WELDER CERTIFICATION RECORDS ARE TO BE DOCUMENTED, MAINTAIN AND AVAILABLE FOR INSPECTION/VERIFICATION.

COMPATIBLE UNIT 1'-6" x 6'-10" SLAB FOR SIDEWALK MANHOLES			
QUANTITY	STOCK #	DESCRIPTION	EA
17'-0"		CORNER L 3 1/2" x 3 1/2" x 1/2"H	
7'-9"	9700-0024	REBAR SIZE #4	
26'-8"	9700-0023	REBAR SIZE #3	
	DESIGNATION	DESCRIPTION	STOCK NO.
	MHRS715SMY	SLAB 7 x 1.5 SDWK ROOF	9721-0646

DRAWN: LKD | DVLPED: CER | DATE: 02-10-82 | REVIEWED: TWM DATE: 8/8/08 | APPRVD: MDW DATE: 8/29/08 | NEXT REVIEW: 8/11 | REV: B



DISTRIBUTION
STANDARDS

1'-6" x 6'-10" FLUSH TYPE ROOF
SLAB FOR SIDEWALK MANHOLES