

ALL BEARING BARS 4" X 3/8" ON 1-3/8" CENTERS.  
 ALL SPECIAL GRATING FILLER BARS 2" X 3/16" ON SAME CENTERS.  
 ALL BARS FLUSH WITH TOP.

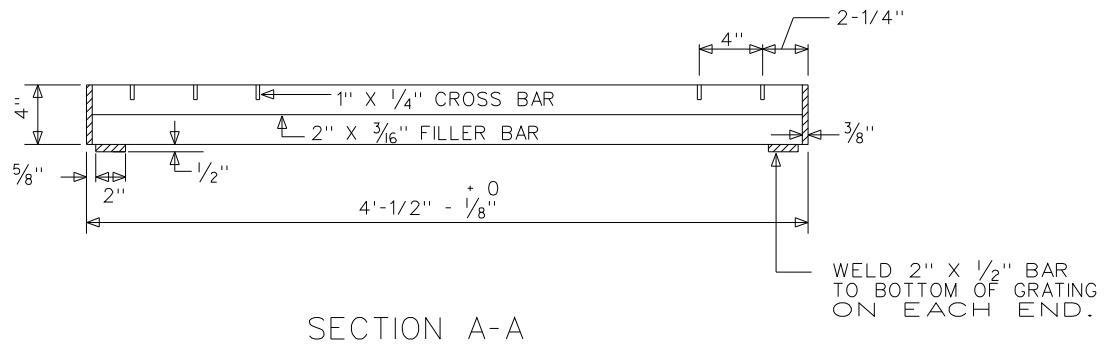
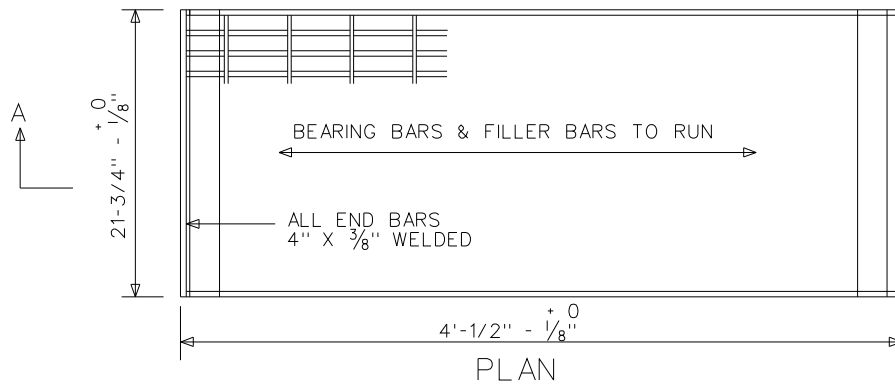

NOTES:

1. GRATING TO WITHSTAND AASHTO H-20 LOADING AS A MINIMUM. MANUFACTURER TO SPECIFY MAXIMUM STRESS USED.
2. MANUFACTURER TO USE A-36 STEEL OR APPROVED EQUIVALENT.
3. GRATING TO BE WELDED TYPE OR APPROVED EQUIVALENT.
4. ALL MATERIAL TO BE GALVANIZED AFTER SHOP WORK AND SHALL CONFORM TO THE LATEST REVISION OF A.S.T.M. A-123.
5. THE FACE OF THE 2" X 1/2" BAR ON THE BOTTOM OF THE GRATING IS TO BE GROUND TO A TRUE PLANE AND THEN GALVANIZED AND SMOOTHED OFF.
6. APPROXIMATE WEIGHT 399\*.
7. STOCK NUMBER 9721-0633.
8. COMPATIBLE UNIT DESIGNATION MHSG4X2RMY.

SPECIAL GRATING NOTES:

1. SPECIAL GRATINGS TO BE USED ONLY IN AREA DESIGNATED FOR PEDESTRIAN TRAFFIC.
2. SPECIAL GRATINGS ARE INTERCHANGEABLE WITH STANDARD GRATINGS. THEY DIFFER ONLY IN A 2" X 3/16" FILLER BAR BETWEEN EACH OF THE BEARING BARS.
3. APPROXIMATE WEIGHT 427\*.
4. COMPATIBLE UNIT DESIGNATION MHSG4X2SRMY.
5. STOCK NUMBER 9721-0644.

DRAWN: JB    DVLDP: JWW    DATE: 4-21-98    REVIEWED: CEG    DATE: 6-29-04    APPRVD: ---    DATE: -----    NEXT REVIEW: 08-07    REV: F



DISTRIBUTION STANDARDS

4'-1/2" X 1'- 9 3/4"  
 ROADWAY GRATING