

PLAN VIEW

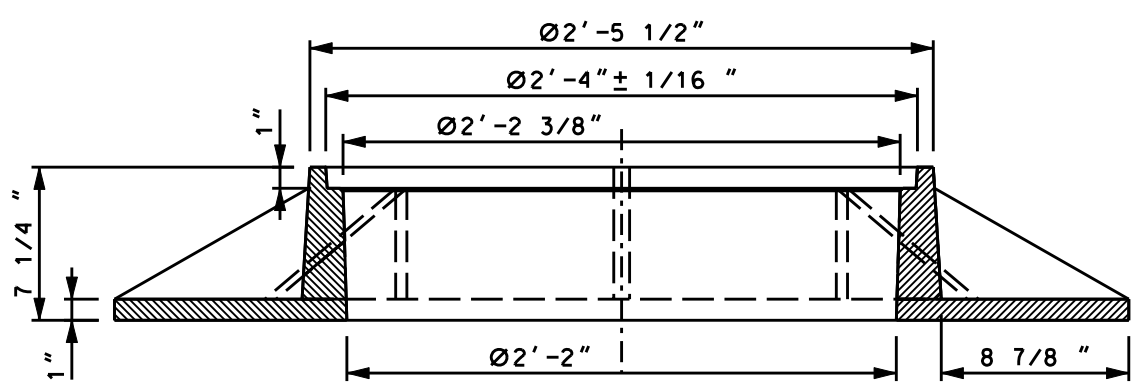

SECTION 1

NOTES:

1. SEE PAGE 2
2. REV. B: CHANGE DWG FORMAT AND CHANGED STOCK No's FOR WMIS

DRAWN:AVI	DVLPED:JR	DATE:3/17/88	REVIEWED:TWM	DATE:9/15/04	APPRVD:MDW	DATE:02-11-08	NEXT REVIEW: 02-11	REV: B
-----------	-----------	--------------	--------------	--------------	------------	---------------	--------------------	--------



POWER DISTRIBUTION STANDARDS

28" MANHOLE COVER FRAME ROADWAY TYPE

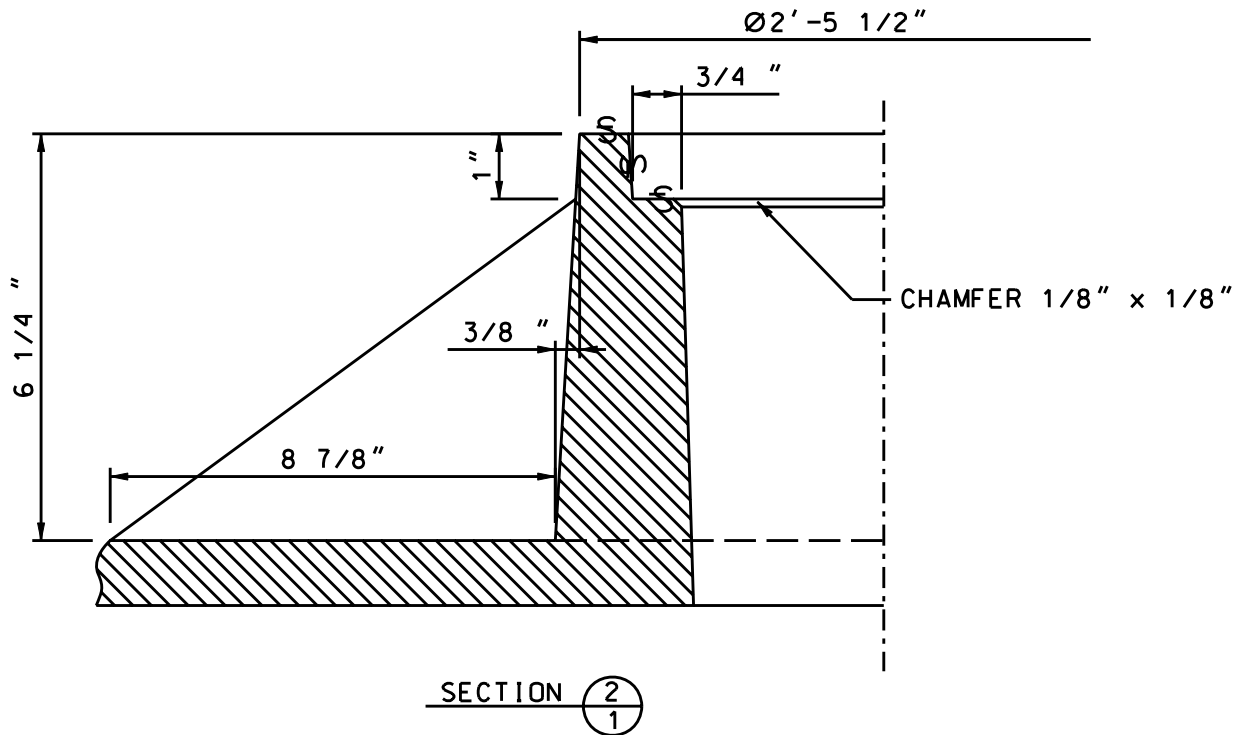

NOTES:

1. ALL CASTING SHALL CONFORM TO STANDARD SPECIFICATIONS FOR GRAY IRON CASTINGS A.S.T.M. DESIGNATION A-48-83 CLASS 35 TOGETHER WITH LATEST REVISIONS THEREOF.
2. STOCK NO. 9721-0624 SHALL APPEAR ON THE CASTING. APPROXIMATIV WEIGHT 820LBS.
3. $\&$ MACHINE FINISH.
4. EACH CASTING SHALL BE IDENTIFIED WITH THE MANUFACTURER'S NAME OR LOGO
5. CASTINGS SHALL BE FREE FROM SAND OR BLOW HOLES AND SHARP EDGES.
6. WITH EXCEPTION ONLY TO ANY NOTED TOLERANCES, NO DIMENSION SHALL EXCEED $\pm 1/16$ " / FT.
7. SEE DWG 4-2-0424 FOR 28" MH COVER
8. REV B: CHANGED DWG FORMAT AND CHANGED STOCK NO'S PER WMIS.

COMPATIBLE UNIT 28" MANHOLE COVER FRAME ROADWAY TYPE		
QTY	STOCK#	DESCRIPTION
1	9721-0624	FRAME HANDHOLE COVER 28" OPENING ROADWAY
	DESIGNATION	DESCRIPTION
	MHCF28RMY	MH COV FRAME 28" RDWY ML CO

DRAWN: AVI | DVLPEO: JR | DATE: 3/17/88 | REVIEWED: TWM DATE: 9/15/04 | APPRVD: MDW DATE: 02-21-08 | NEXT REVIEW: 02-11 | REV: B



POWER
DISTRIBUTION
STANDARDS

28" MANHOLE COVER
FRAME ROADWAY TYPE